



# Technical Data

## Vertical In-line Pump - EG65-5020-02204

Revision no.

Page:  
 1

Company name  
 Respons. Department  
 Person in charge  
 Phone number  
 Fax no  
 E-mail address

Receiver

From





**Brand: Gol Pumps**  
**Model: EG65-5020-02204**

Motor (V1)	
Model	hp
Y2-100L1-4	3

Weight (lb)		
Pump	Motor	Pump & motor
119	75	192

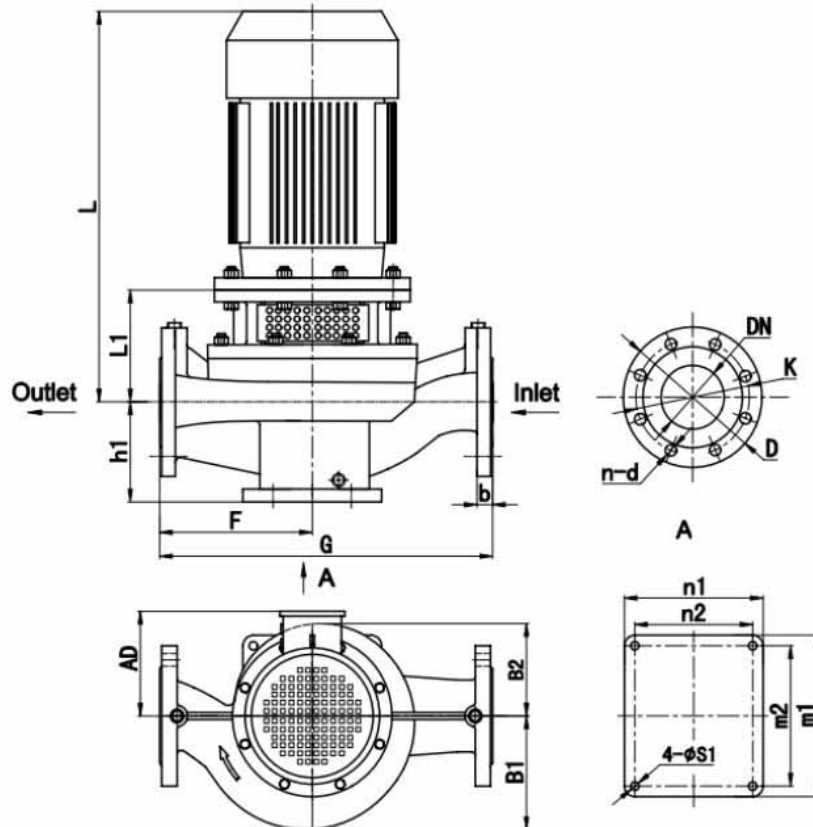
**Dimensions:**



Pump installation size (inch)															
h1	L1	F	G	L	AD	B1	B2	n2 x m2	n1 x m1	s1	DN	D	K	n - d	b
5.4	6.5	9.4	18.9	19.7	7.1	6.2	5.6	6.7 x 7.9	7.9 x 9.1	0.6	2.6	7.3	5.7	4 - φ18	0.8

Project	Project ID	Created by	Created on	Last update
---------	------------	------------	------------	-------------



# Performance Curves

## Vertical In-line Pump - EG65-5020-02204

Revision no.

Page:  
 2

Receiver \_\_\_\_\_ From \_\_\_\_\_

Company name \_\_\_\_\_  
 Respons. Department \_\_\_\_\_  
 Person in charge \_\_\_\_\_  
 Phone number \_\_\_\_\_  
 Fax no \_\_\_\_\_  
 E-mail address \_\_\_\_\_

Model	Capacity			Head		Speed	Motor	Voltage	Phase	Impeller Diam.	
	m <sup>3</sup> /h	l/s	gpm	m	ft	r/min	hp	v		mm	inch
EG65-5020-02204	16	5.2	70.4	16.2	53	1750	3	230	1	185	7.3
	26	9	114.5	14	46		3				
	31.1	10.4	136.9	12	39.2		3				

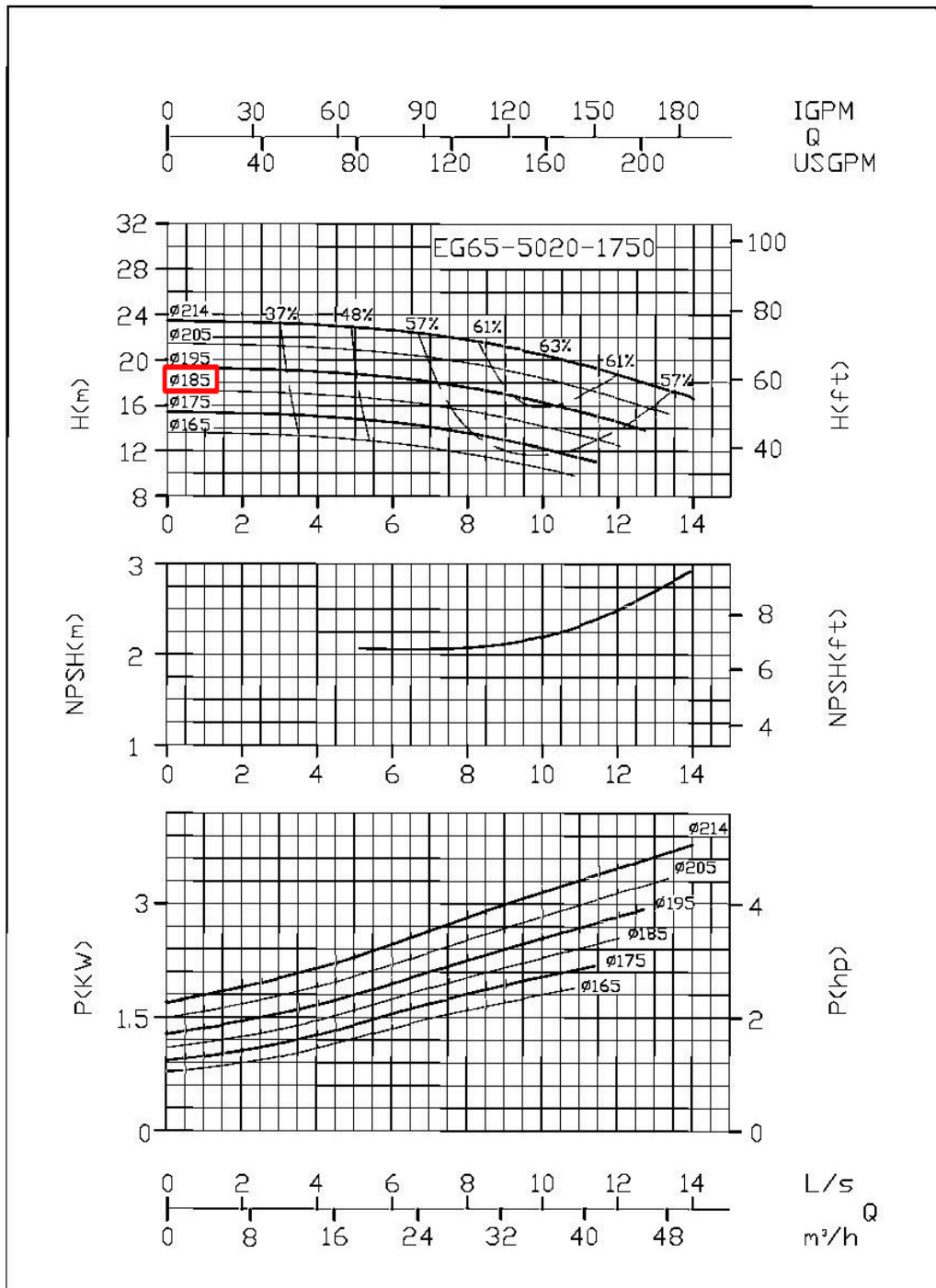

Project	Project ID	Created by	Created on	Last update
---------	------------	------------	------------	-------------