

TANK 322

60 Hz

High Chrome Dewatering Pump

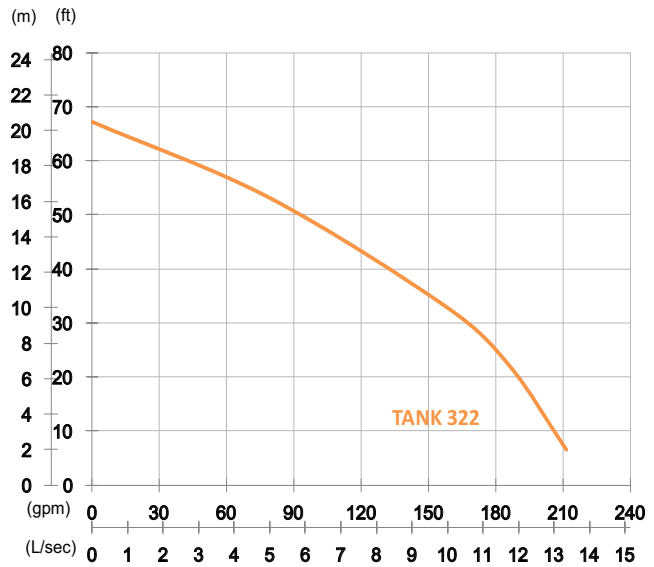

Shaft Speed : 3450 rpm

Outlet : 80mm, 3in

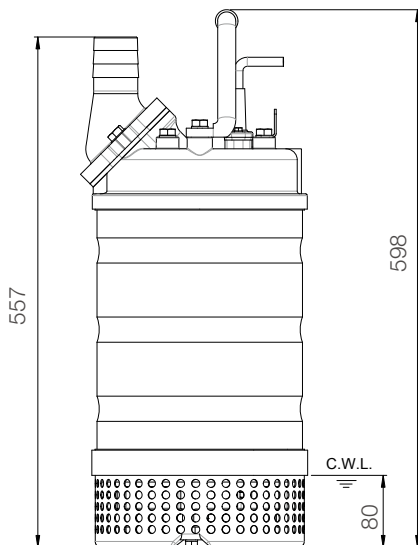
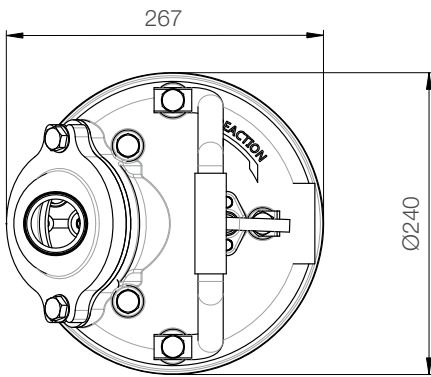

unit : mm

Weight : 35kg / 77 lbs

OUTPUT	HEAD	FLOW
2.2 kW	Rated : 10m, 33ft	Rated : 10 L/s, 159 gpm
3 HP	Max : 20.5m, 67ft	Max : 13.3 L/s, 211 gpm

Solid Passage : 9mm, 0.4in

Pump Type	Electric Submersible Pumps	
	3-Phase, 220V	
Motor	Type	Induction Motor
	Poles	2 Pole
	Insulation	Class F
	Protector	Circle Thermal Protector
	Starter	3-Phase · D.O.L.
Lubricant	Food Grade (ISO VG32)	
Impeller Type	Opened	
Shaft Seal	Double Mechanical Seal	
	Silicon Carbide VS Ceramic / Carbon	
Bearings	C3 Shielded ball bearings	
Cable	PVC (CSA Certified) / H07BQ-F	
	10m (33ft) or longer upon request.	
Materials	Pump Casing	Gray Iron
	Impeller	Chromium Iron
	Motor Frame	Stainless Steel
	Motor Shaft	Stainless Steel
	Strainer	Stainless Steel
Max. Liquid Temperature	40°C (104°F)	
Max. Submersion Depth	20m (66ft)	
pH Range	pH 5 - pH 8	