



Technical Data

Vertical In-line Pump - EGM50-3216-01104

Revision no.

 Page:
1

Receiver

From

 Company name
 Respons. Department
 Person in charge
 Phone number
 Fax no
 E-mail address

Brand: Gol Pumps
Model: EGM50-3216-01104
Flange: ANSI Class 125

Motor (V1)

Model	HP
Y2-90S-4	1.5

Weight (lb)

Pump	Motor	Pump & Motor
79.2	48.4	129.8

Inlet Outlet

2"	2"
----	----

Dimensions:

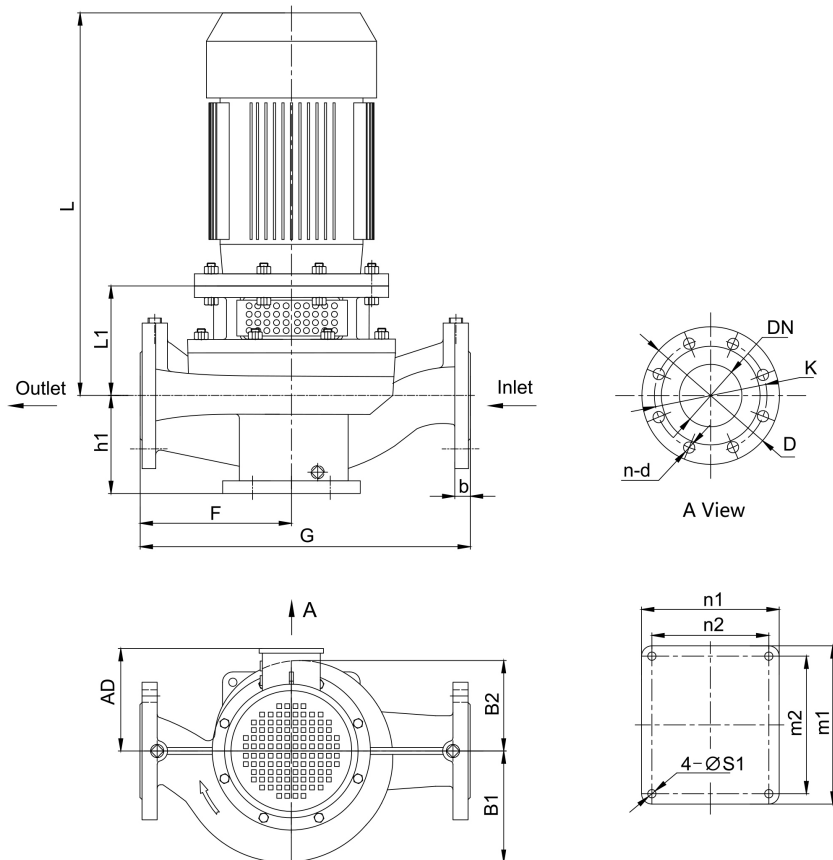

Pump Installation Size (inch)

h1	L1	F	G	L	AD	B1	B2	n2 x m2	n1 x m1	S1	DN	D	K	n - d	b
4.6	6	6.3	12.6	16.6	6.1	4.5	4.5	6.7x7.9	7.9x9.1	0.5	2	5.9	4.8	4 - ϕ 0.8	-

Project

Project ID

Created by

Created on

Last update



Performance Curves

Vertical In-line Pump - EGM50-3216-01104

Revision no.

Page:
 2

Receiver From

Company name
 Respons. Department
 Person in charge
 Phone number
 Fax no
 E-mail address

Model	Capacity			Head		Speed	Motor	Voltage	Phase	Impeller Diam.		Eff.	(NPSH)r
	m ³ /h	l/s	gpm	m	ft	r/min	hp	v		mm	inch	%	ft
EGM50-3216-01104	9	2.5	39.9	13.7	45	1710	1.5	230/460	3	174	6.8	48	9.5
	15.1	4.2	66.6	11.7	38		1.5					56	12.5
	18	5	79.9	10.1	33		1.5					52	16.1

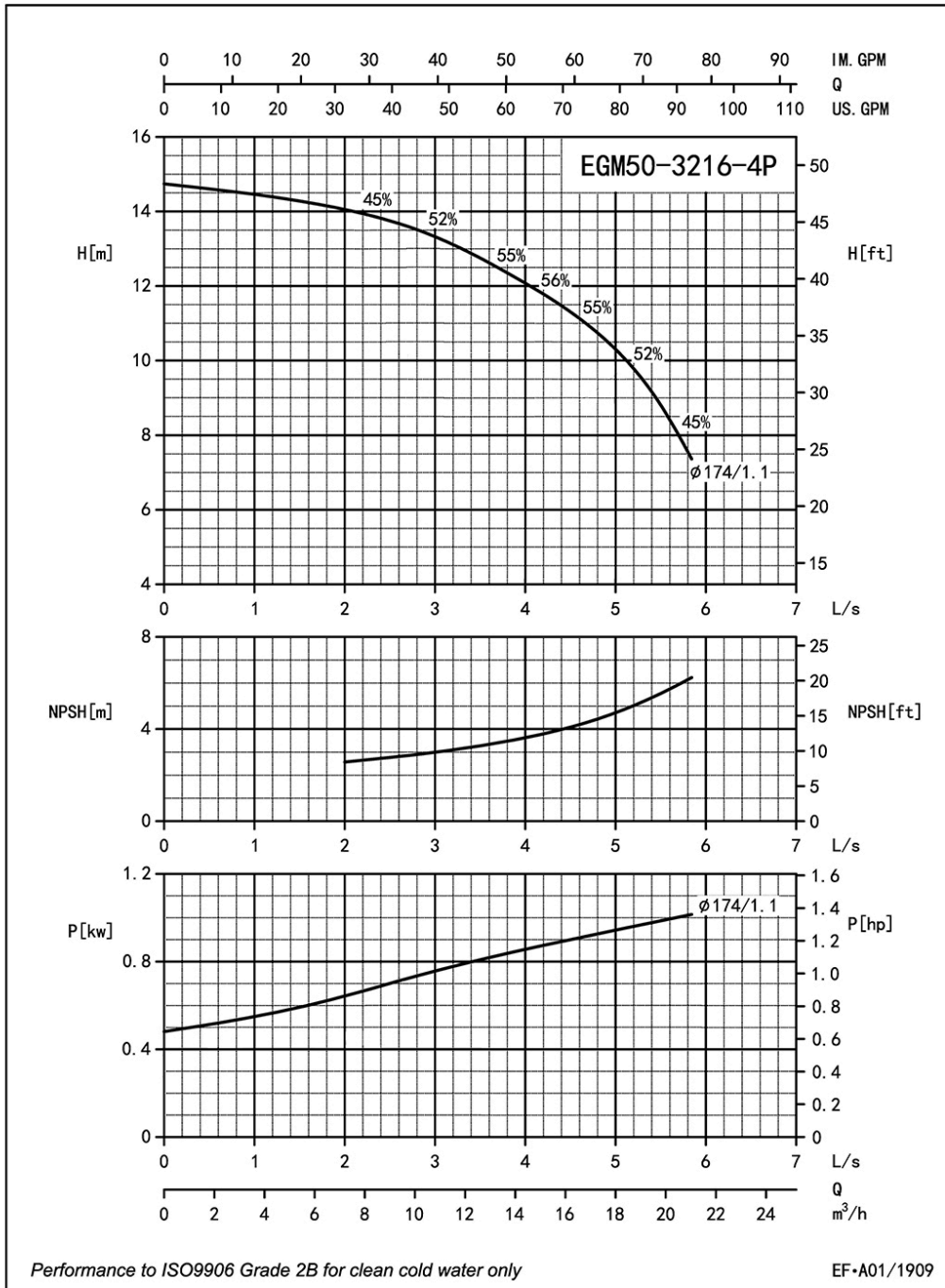

Project	Project ID	Created by	Created on	Last update
---------	------------	------------	------------	-------------



Parts List

Vertical In-line Pump - EGM50-3216-01104

Revision no.

Page:

3

Receiver

From

 Company name
 Respons. Department
 Person in charge
 Phone number
 Fax no
 E-mail address

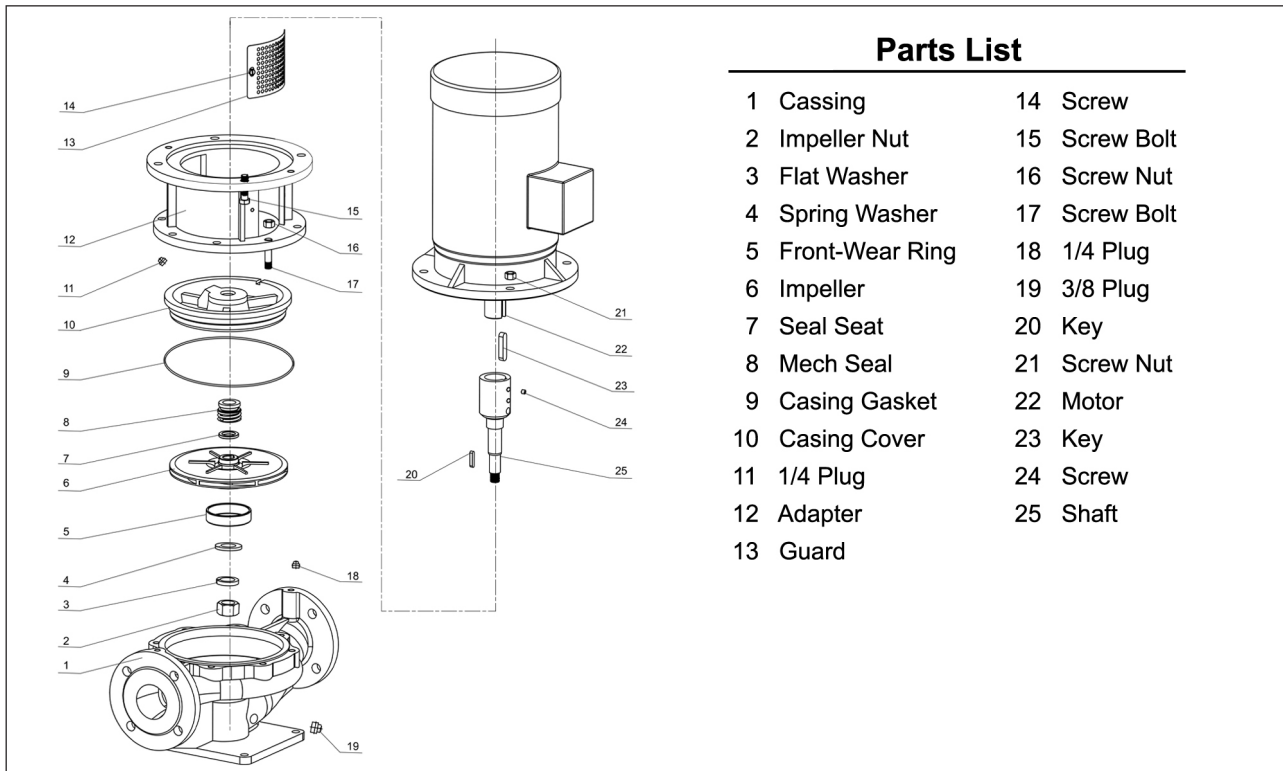

Project

Project ID

Created by

Created on

Last update