



Technical Data

Vertical In-line Pump - EGM65-4016-01104

Revision no.

 Page:
1

Receiver

From

 Company name
 Respons. Department
 Person in charge
 Phone number
 Fax no
 E-mail address

Brand: Gol Pumps
Model: EGM65-4016-01104
Flange: ANSI Class 125

Motor (V1)

Model	HP
Y2-90S-4	1.5

Weight (lb)

Pump	Motor	Pump & Motor
94.6	48.4	143

Inlet Outlet

2.5"	2.5"
------	------

Dimensions:

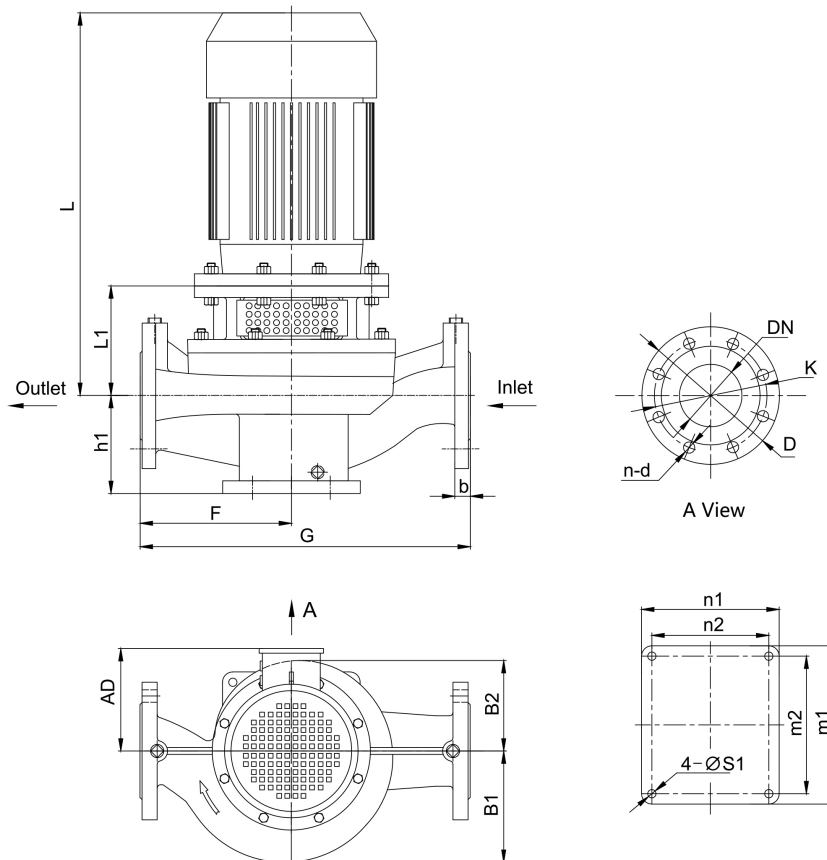

Pump Installation Size (inch)

h1	L1	F	G	L	AD	B1	B2	n2 x m2	n1 x m1	S1	DN	D	K	n - d	b
5.4	6	6.9	14.6	16.6	6.1	5	4.5	6.7x7.9	7.9x9.1	0.5	2.5	7.1	5.5	4 - ϕ 0.8	-

Project

Project ID

Created by

Created on

Last update



Performance Curves

Vertical In-line Pump - EGM65-4016-01104

Revision no. _____

Page: 2

Receiver	From

Company name _____
 Respons. Department _____
 Person in charge _____
 Phone number _____
 Fax no _____
 E-mail address _____

Model	Capacity			Head		Speed	Motor	Voltage	Phase	Impeller Diam.		Eff.	(NPSH)r
	m ³ /h	l/s	gpm	m	ft	r/min	hp	v		mm	inch	%	ft
EGM65-4016-01104	11.5	3.2	50.4	12.4	41	1710	1.5	230/460	3	167	6.6	54	6.6
	19.1	5.3	84	11	36		1.5					63	9.8
	23	6.4	100.8	9	30		1.5					57	11.5

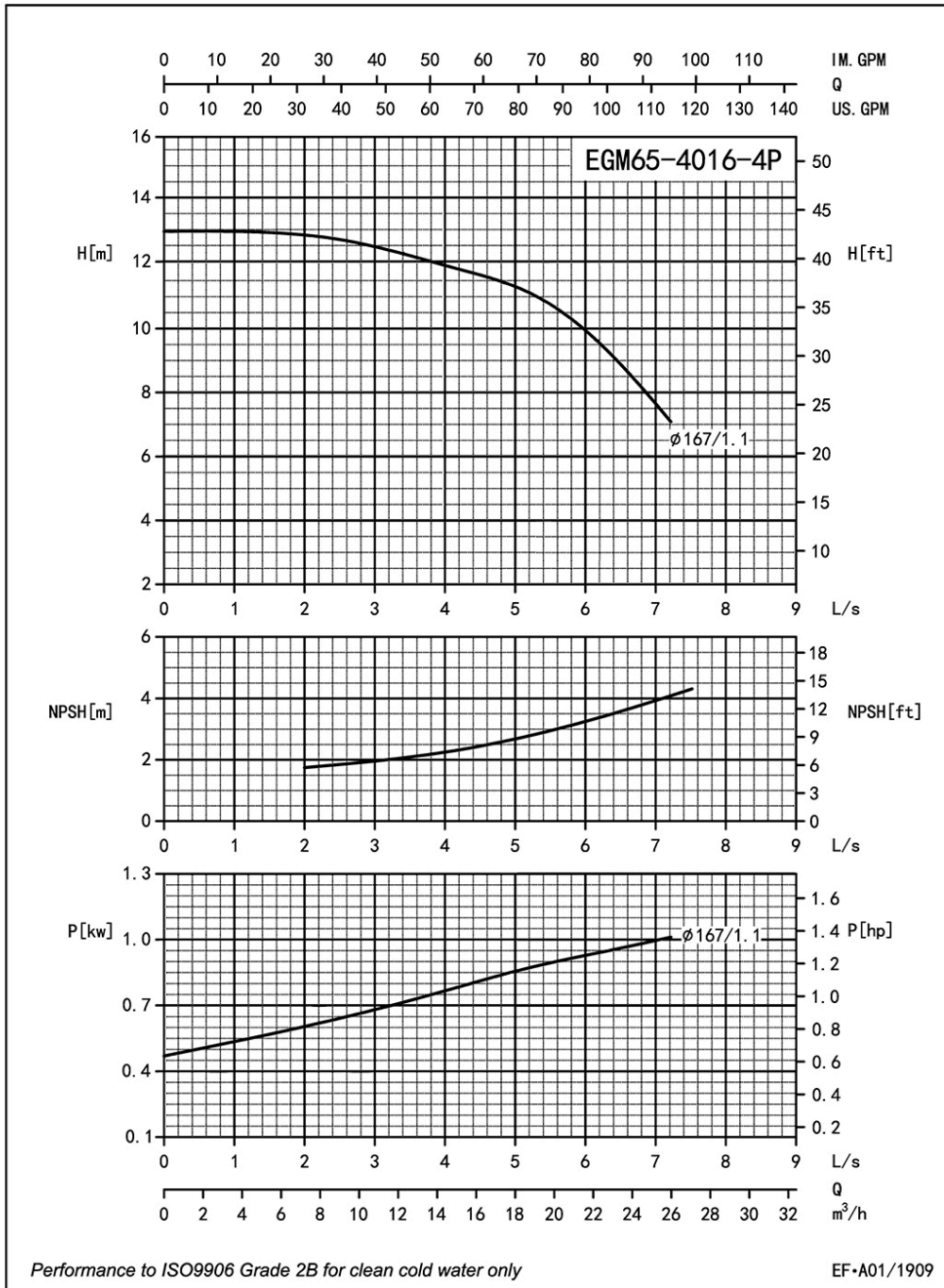

Project	Project ID	Created by	Created on	Last update



Parts List

Vertical In-line Pump - EGM65-4016-01104

Revision no.

Page:
 3

Receiver

From

Company name
 Respons. Department
 Person in charge
 Phone number
 Fax no
 E-mail address

Parts List

1 Cassing	14 Screw
2 Impeller Nut	15 Screw Bolt
3 Flat Washer	16 Screw Nut
4 Spring Washer	17 Screw Bolt
5 Front-Wear Ring	18 1/4 Plug
6 Impeller	19 3/8 Plug
7 Seal Seat	20 Key
8 Mech Seal	21 Screw Nut
9 Casing Gasket	22 Motor
10 Casing Cover	23 Key
11 1/4 Plug	24 Screw
12 Adapter	25 Shaft
13 Guard	

Project	Project ID	Created by	Created on	Last update
---------	------------	------------	------------	-------------