



Technical Data

Vertical In-line Pump - EGM65-4016-01504

Revision no.

Page:

1

Receiver

From

 Company name
 Respons. Department
 Person in charge
 Phone number
 Fax no
 E-mail address

Brand: Gol Pumps
Model: EGM65-4016-01504
Flange: ANSI Class 125

Motor (V1)

Model	HP
Y2-90L-4	2

Weight (lb)

Pump	Motor	Pump & Motor
94.6	59.4	151.8

Inlet Outlet

2.5"	2.5"
------	------

Dimensions:

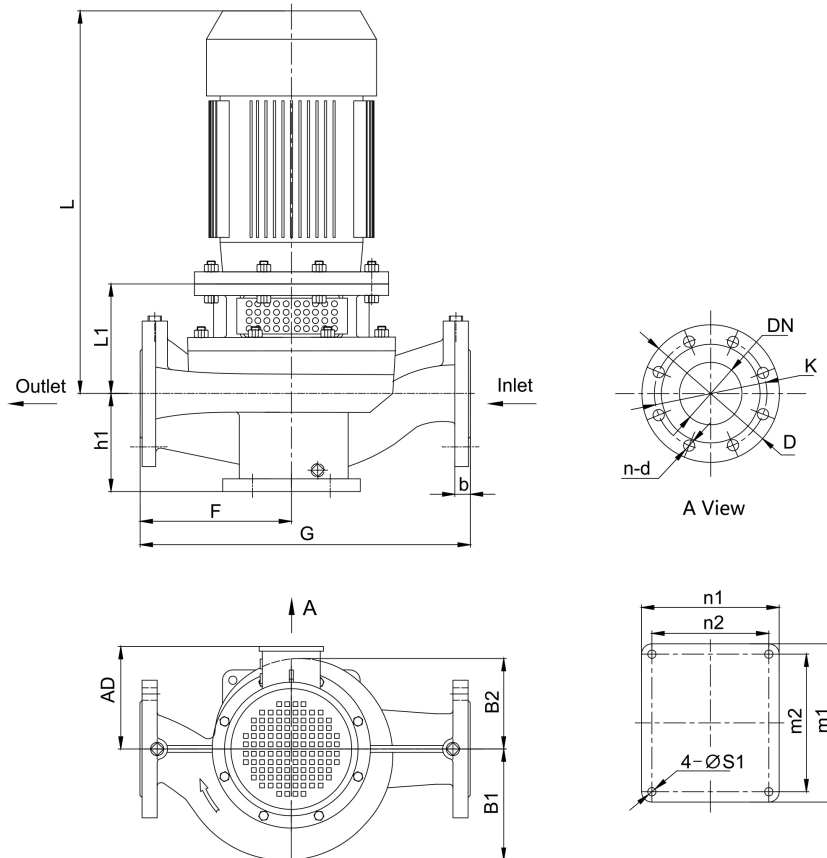

Pump Installation Size (inch)

h1	L1	F	G	L	AD	B1	B2	n2 x m2	n1 x m1	S1	DN	D	K	n - d	b
5.4	6	6.9	14.6	17.6	6.1	5	4.5	6.7x7.9	7.9x9.1	0.5	2.5	7.1	5.5	4 - ϕ 0.8	-

Project

Project ID

Created by

Created on

Last update



Performance Curves

Vertical In-line Pump - EGM65-4016-01504

Revision no.

Page:
 2

Receiver	From
Company name Respons. Department Person in charge Phone number Fax no E-mail address	

Model	Capacity			Head		Speed r/min	Motor hp	Voltage v	Phase	Impeller Diam.		Eff. %	(NPSH)r ft
	m ³ /h	l/s	gpm	m	ft					mm	inch		
EGM65-4016-01504	11.5	3.2	51.4	13.5	44	1710	2	230/460	3	174	6.9	54	6.6
	19.4	5.4	85.6	12	39		2					65	9.8
	23.4	6.5	102.7	10.2	33		2					60	11.5

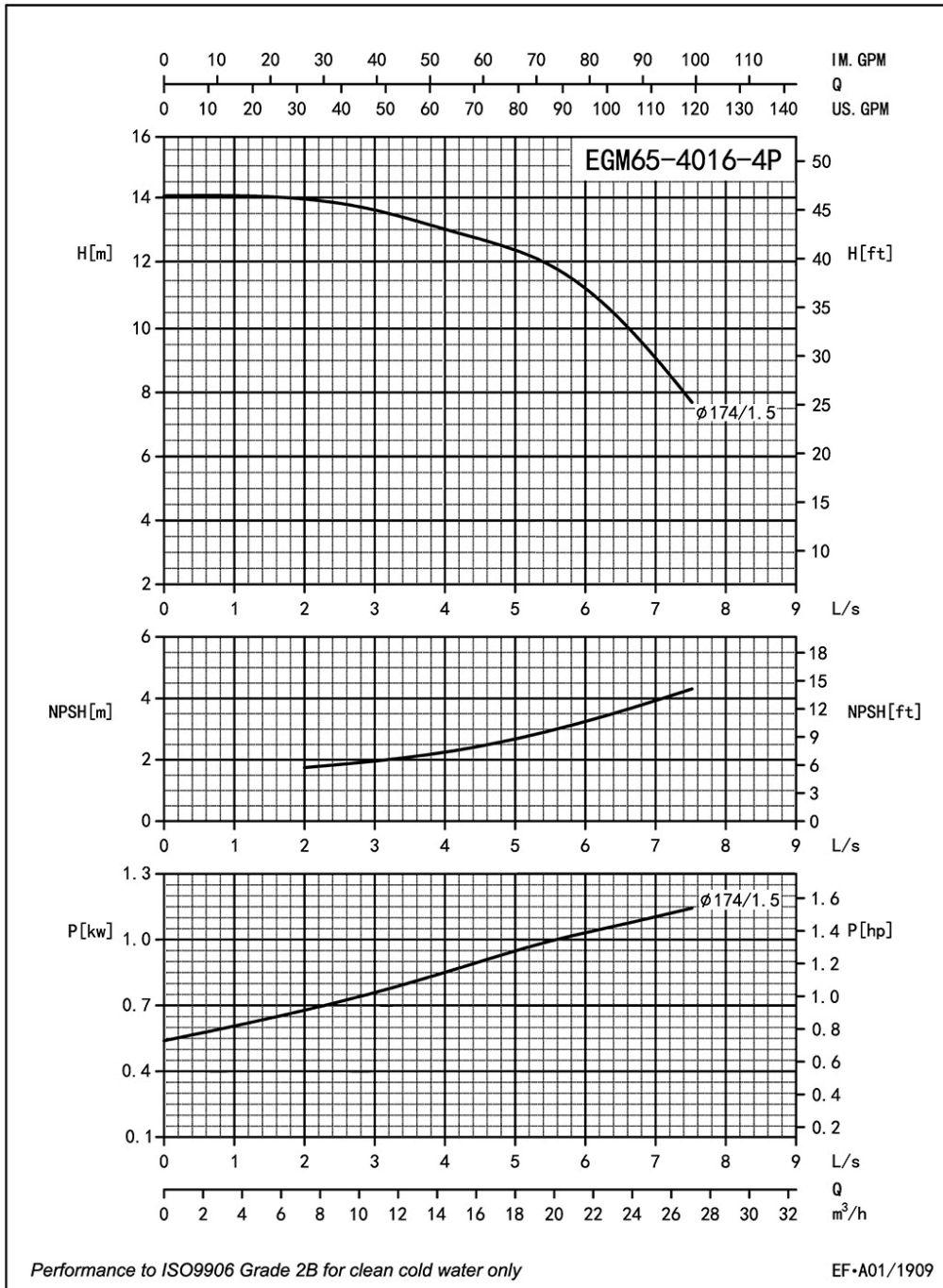

Project	Project ID	Created by	Created on	Last update
---------	------------	------------	------------	-------------



Parts List

Vertical In-line Pump - EGM65-4016-01504

Revision no.

Page:

3

Receiver

From

 Company name
 Respons. Department
 Person in charge
 Phone number
 Fax no
 E-mail address

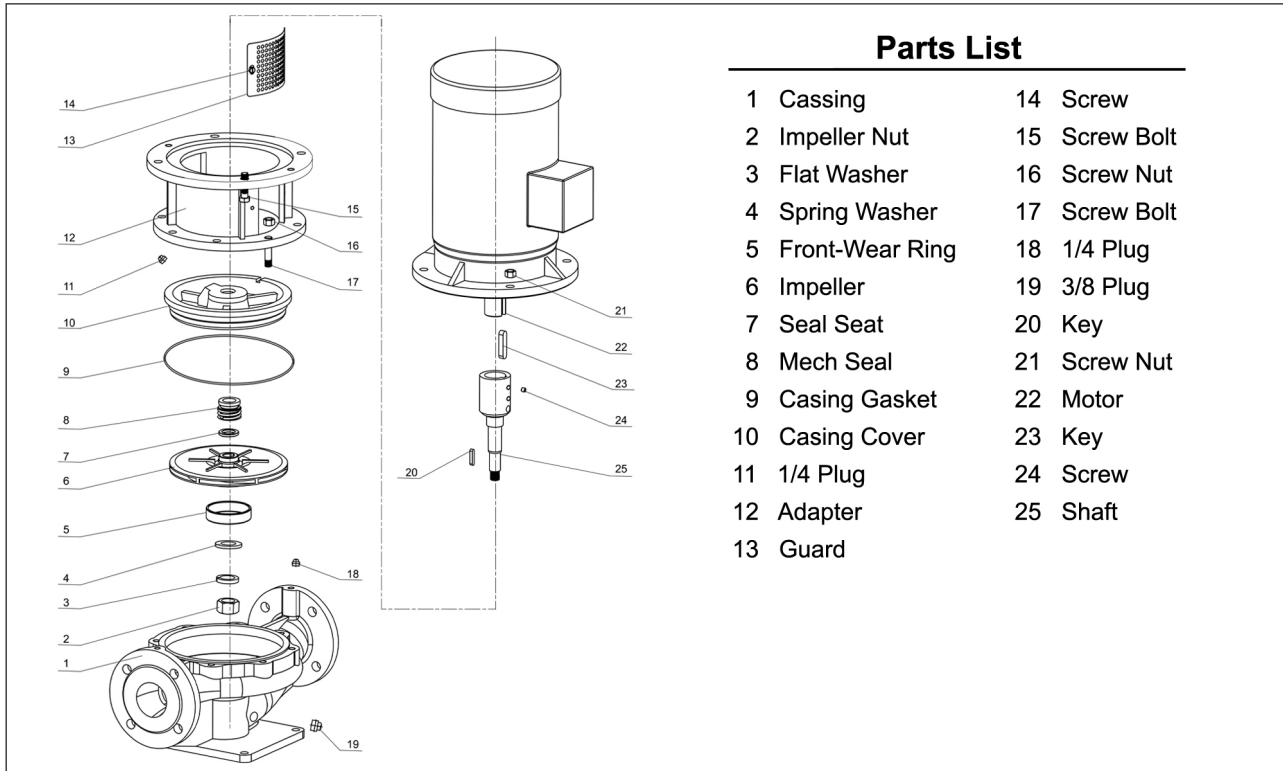

Project

Project ID

Created by

Created on

Last update