



Technical Data

Vertical In-line Pump - EGM100-8026-15004

Revision no.

Page:

1

Receiver

From

 Company name
 Respons. Department
 Person in charge
 Phone number
 Fax no
 E-mail address

Brand: Gol Pumps
Model: EGM100-8026-15004
Flange: ANSI Class 125

Motor (V1)

Model	HP
Y2-160L-4	20

Weight (lb)

Pump	Motor	Pump & Motor
217.8	283.8	501.6

Inlet Outlet

4"	4"
----	----

Dimensions:

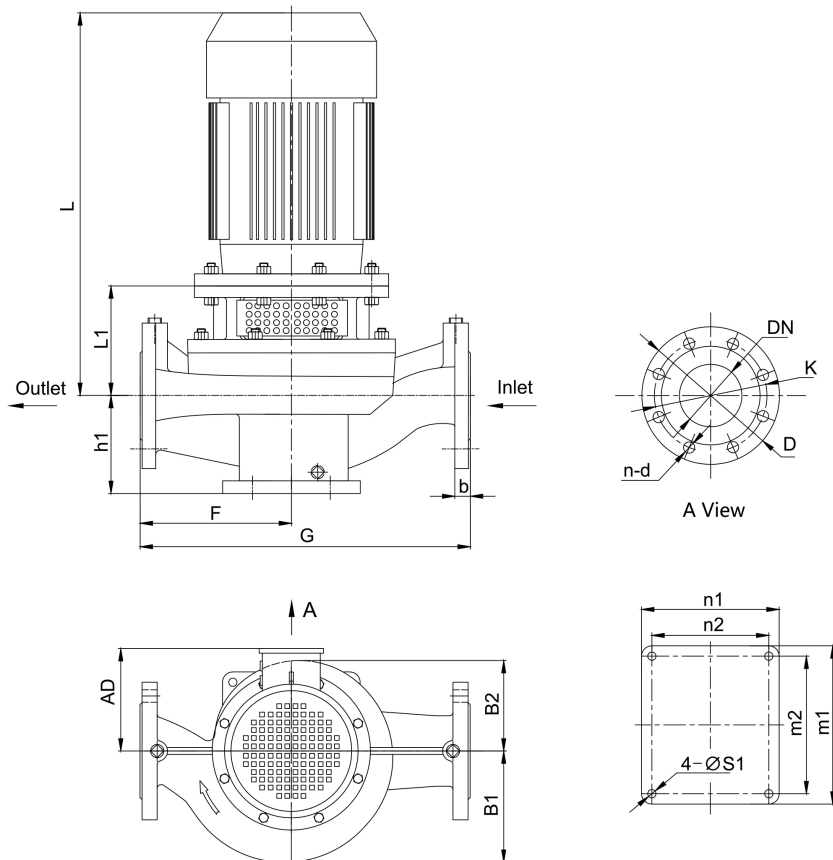

Pump Installation Size (inch)

h1	L1	F	G	L	AD	B1	B2	n2 x m2	n1 x m1	S1	DN	D	K	n - d	b
7.4	9.2	12.2	24.8	31.3	10	8.2	7.2	6.7x7.9	7.9x9.1	0.6	4	9.1	7.5	8 - ϕ 0.8	-

Project

Project ID

Created by

Created on

Last update



Performance Curves

Vertical In-line Pump - EGM100-8026-15004

Revision no.

Page:

2

Receiver

From

 Company name
 Respons. Department
 Person in charge
 Phone number
 Fax no
 E-mail address

Model	Capacity			Head		Speed	Motor	Voltage	Phase	Impeller Diam.		Eff.	(NPSH)r
	m ³ /h	l/s	gpm	m	ft	r/min	hp	v		mm	inch	%	ft
EGM100-8026-15004	71.3	19.8	313.8	32	105	1760	20	230/460	3	255	10	68	8.9
	118.8	33	523.1	28	92		20					77	11.2
	142.6	39.6	627.7	25	82		20					74	13.1

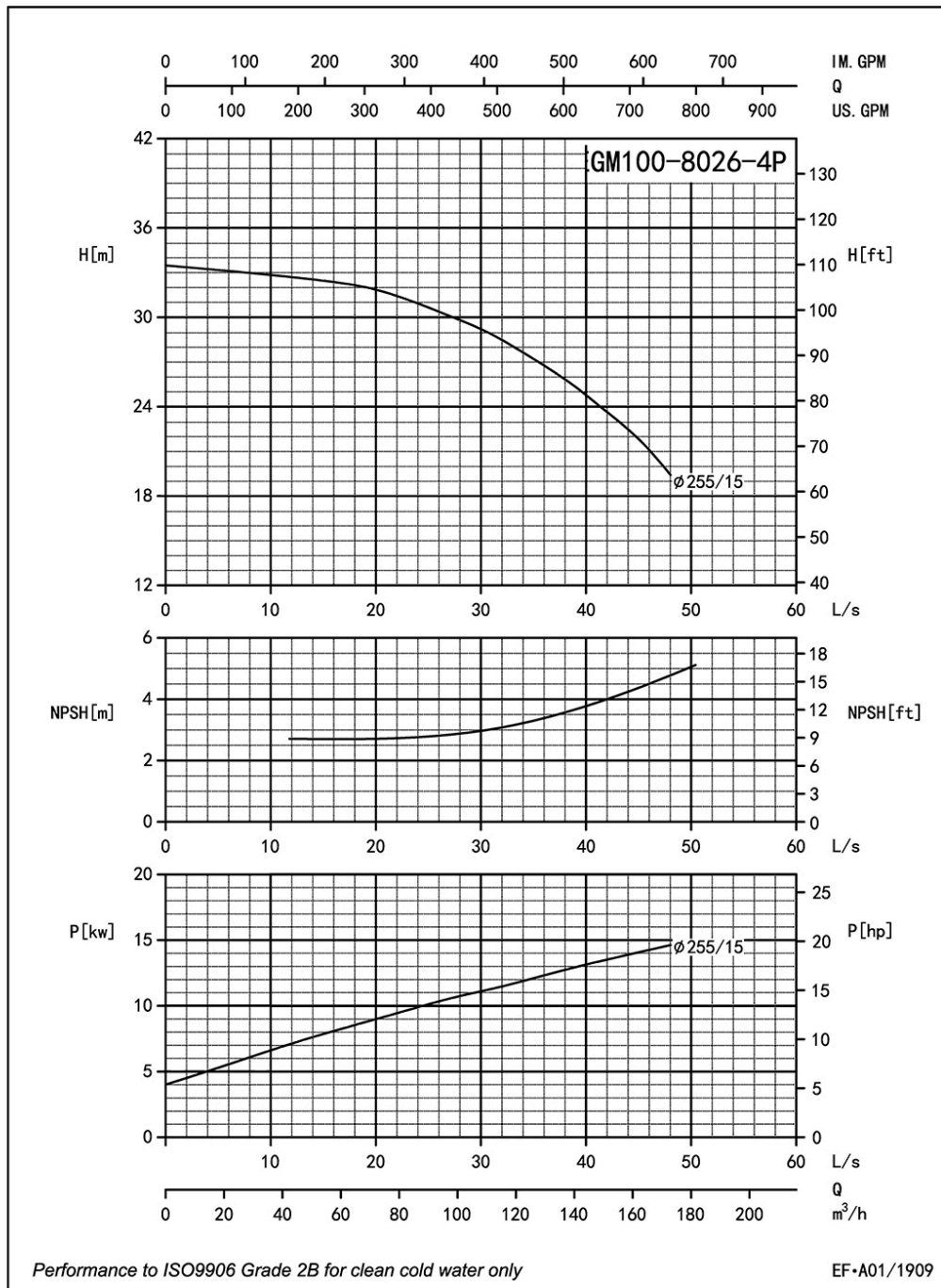

Project

Project ID

Created by

Created on

Last update



Parts List

Vertical In-line Pump - EGM100-8026-15004

Revision no.

Page:
3

Receiver

From

Company name
Respons. Department
Person in charge
Phone number
Fax no
E-mail address

Parts List

1	Cassing	14	Screw
2	Impeller Nut	15	Screw Bolt
3	Flat Washer	16	Screw Nut
4	Spring Washer	17	Screw Bolt
5	Front-Wear Ring	18	1/4 Plug
6	Impeller	19	3/8 Plug
7	Seal Seat	20	Key
8	Mech Seal	21	Screw Nut
9	Casing Gasket	22	Motor
10	Casing Cover	23	Key
11	1/4 Plug	24	Screw
12	Adapter	25	Shaft
13	Guard		

Project	Project ID	Created by	Created on	Last update
---------	------------	------------	------------	-------------